



U.V. Scanner

Model 5600-91



About This Scanner

This sensor features a high temperature and high sensitivity ultraviolet (U.V.) tube for monitoring gas or oil flames in applications that cycle on and off frequently. The scanner is UL listed, CSA certified and FM approved when used with Eclipse model 5600 Veri-Flame, model 6000 Multi-Flame, model 6500 Bi-Flame, or model 7000 Peek-A-Flame. This product is also in conformance with the "CE Mark" Directives when used with the model VF56 Veri-Flame CE as listed in its Instruction Manual 818-2. It comes with a 6 ft flexible metal cable and an insulated coupling.



The UV tube is made of quartz and is filled with a gas that surrounds two electrodes. These electrodes are energized continuously by a high voltage. The gas acts as an insulator in the absence of UV radiation. Combustion produces UV radiation to ionize the gas and causes current pulses to flow between the electrodes. These current pulses result in a flame signal which is transmitted to the amplifier in the control, where it is processed to energize or hold in the flame relay.

1.0 Specifications

Supply Voltage	425 \pm 25VDC (nominal supply from control)
Supply Current	0.3 mA
Wiring	6 ft. (183 cm) flexible 3/8" metal conduit with two #18 AWG conductors
Temperature Range	-4° to 257°F (-20° to +125°C)
Materials	Housing: aluminum Conduit: plated steel Insulated Coupling: PBT polyester, glass reinforced
Weight	13 oz. (360 grams)
Options	Magnifying lens assembly (Part #49600-98) Heat Block Seal 23HBS (Part #400011)

2.0 Sensor Installation



Warning: Incorrect sensor installation may cause the sensor to generate a false flame signal. This can cause unburned fuel to collect in the combustion chamber, resulting in explosions, injuries, and property damage. Be certain that the flame sensor detects only the pilot and/or main flame of the intended burner by testing the control system under varying operating conditions and firing rates. Follow the test procedures given in this manual and the equipment provider's instructions after installation and at regularly scheduled maintenance intervals.

2.0 Sensor Installation (Continued)

Sensor Wiring

Route sensor wiring a sufficient distance from ignition and other high voltage wiring to avoid electrical interference. Some areas may have high levels of electromagnetic fields or ground currents that require the use of special cables, isolation and grounding methods. Figure 1 illustrates the sensor wiring to appropriate Eclipse controls. The blue wire supplies power and carries the flame signal, the yellow wire connects to circuit common, and the flexible metal conduit must be connected to earth ground.

If sensor wiring is to extend beyond the supplied 183 cm (6 ft.) length, use conductors sized from #14 to #18 AWG and rated for at least 75°C (167°F) and 600 volt insulation.

On wiring runs less than 20 ft. (6 m) and that have at least one foot of separation from ignition and other high voltage conductors may use unshielded wiring if each scanner has its own dedicated conduit. For wiring runs greater than 20 ft. (6 m) use two-conductor shielded cable (such as Belden #8719 or #9342, or for extreme temperatures #83322E). For multiple burner installations, shielded cables can be run in a common conduit. Use isolated shielded pairs to avoid the possibility of interference (cross-talk) between wiring of multiple scanners. The success of wiring runs of 150 ft. (45 m) or more is dependent upon site conditions; therefore the equipment layout should be redesigned to allow the control to be mounted closer to the burner. For these longer wiring runs, it may be necessary to use a pair of RG62A/U coax cables (Eclipse #21741) per scanner, with the shielding tapered and not grounded.

Figure 1
UV Scanner Wiring

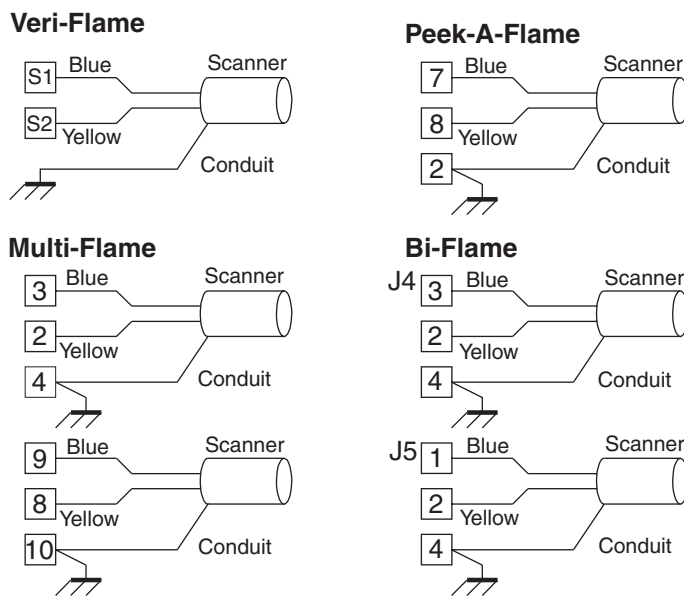
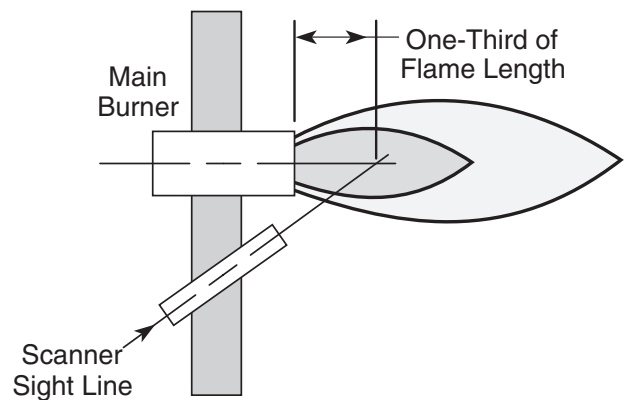

Figure 2
UV Scanner Sighting



Sensor Installation

In most cases, the location for this scanner will be pre-determined by the burner manufacturer. However proper application of this scanner requires knowledge of the burner, the combustion chamber, and the process. Opposing burners, flame swirl patterns, and substance in the line-of-sight may require special mounting techniques.



Caution: The UV tube is fragile. Handle carefully and avoid dropping or sharp blows.

- Consult the burner manufacturer's instructions for mounting location. The scanner should view the intersection of the pilot and main flames. It typically should be aimed at the first third of the flame closest to the burner nozzle, see Figure 2. Certain unburned hydrocarbons, oil mist, recirculated flue gas or other contaminants may mask and absorb the ultraviolet radiation.
- Position the scanner within 18 inches (457 mm) of the flame. Longer distances are allowed, but could limit the field of view and may reduce the turndown or firing range of the burner.

2.0 Sensor Installation (Continued)

- Mount the scanner to a 1/2" N.P.T. pipe nipple to the burner. Insure that the scanner body does not exceed +125°C (257°F) from conducted, radiated, or ambient temperature. To protect from high temperatures, use the 1/2" F.N.P.T. insulated coupling (#49099) with a heat block seal (#400011) and source of clean purging air (5 CFM typical), or a purge assembly constructed with a 1/2" WYE fitting.
- Keep the scanner lens and line-of-sight free of contamination. Be aware that scanners looking up are susceptible to dirt and dust settling. Soot, steam, and unburned hydrocarbons may reduce or even mask the radiation from the flame. A purging assembly as described above may alleviate these problems.
- Some burners have an open construction allowing the scanner to view into a furnace. Avoid sighting background sources of UV light. If necessary, mask the offending background source by use of an orifice, the magnifying lens assembly (#49600-98), or a combination of both to reduce the field of view.
- Two Model 5600-91 scanners may be installed on one burner when necessary to view different areas of the flame to obtain reliable operation. The wires should be connected in parallel.

3.0 Test Procedures

Perform the following tests for every new installation and at periodic maintenance intervals. Depending on the burner equipment (such as pilot versus direct spark), some of the tests may not be possible.

Measuring Flame Signal Strength

Insert the positive probe of a 0-15 VDC (100k ohm minimum input impedance) into the test point on the control cover. Connect the negative probe to the GND or terminal for the yellow wire. Readings greater than 4 VDC are adequate.

Minimum Pilot Test

Run this test on pilot ignited burners to ensure that the sensor will not detect a pilot flame too small to reliably light the main flame.

- 1) Manually shut off the fuel supply to the burner, but not to the pilot.
- 2) Put the control in the pilot test mode. On the VeriFlame push the "Test/Reset" button in to the "Test" position ("button in"). On the Bi-Flame and Multi-Flame press the "Reset" and "Enter" buttons together then release the "Reset" and after a few seconds release the "Enter".
- 3) Start the system normally. The control will hold the operating sequence at the pilot flame step.
- 4) Measure the flame signal strength as described above.
- 5) Slowly reduce the pilot fuel until the signal drops out. Increase the pilot fuel slightly and restart the system. Observe the flame signal and adjust the pilot fuel as required to prevent flame failure. This is the minimum pilot.
- 6) Take the control out of the pilot test mode and begin the start-up sequence again. On the VeriFlame push the "Test/Reset" Button again so that it pops out to the "Run" position. On the Bi-Flame and Multi-Flame press the "Reset" button.
- 7) When the sequence reaches the main flame trial for ignition, smoothly restore the fuel supply to the main burner. If the main burner does not light within five seconds, immediately shut off the burner fuel supply, stop the control, and purge the system. Attempt to light the burner again before proceeding with adjustments in the next step.
- 8) For burners with an adjustable scanner sighting assembly, adjust the sighting assembly further away from the nozzle of the pilot flame thus requiring a larger minimum pilot for adequate signal strength. For burners with fixed sighting, increase the pilot flame. Repeat steps 1 through 8 until the main burner lights off smoothly and reliably.

Ignition Interference Test

Test the effect of the ignition system (transformer, spark plug, wiring and grounding) on the flame signal and control. Ignition interference can decrease or increase the flame signal strength or can cause erratic operation of the control. The scanner placement on some burners allows direct sighting of the spark, creating a strong but false flame signal. The Eclipse flame control sequence does not interrupt the spark upon flame detection until after the trial for ignition period. Therefore spark detection is not a problem; however ignition interference should still be reduced or eliminated where possible.

3.0 Test Procedures Ignition Interference Test (Continued)

- 1) Manually shut off the fuel supply to the burner.
- 2) Start the system normally. Observe the flame signal during ignition to see if it responds during the spark. Readings above 2VDC indicate spark interference or spark sighting.
- 3) On pilot ignited burners, manually shut off the fuel supply to the main burner. For direct spark burners, lock the burner firing-rate at the start position.
- 4) Put the control in the pilot test mode (see step 2 of Minimum Pilot Test above).
- 5) Start the system normally. Observe the flame signal during spark and after the trial for ignition. Spark interference causes the signal during the spark to differ more than 2VDC from the signal after the spark.
- 6) If spark interference is observed, try to minimize its affect:
 - a) insure proper grounding for the ignition circuit
 - b) isolate the scanner from ground and/or remove the shield connection from ground
 - c) check for proper spark gap
 - d) clean, repair, or replace faulty wiring and connectors
 - e) separate or shield the scanner wiring from the ignition wiring
 - f) reverse the wires feeding the primary to the ignition transformer
 - g) move the location of the ignition transformer

Pilot Flame Failure Test

- 1) Put the control in the pilot test mode (see step 2 of Minimum Pilot Test above).
- 2) Start the system normally.
- 3) After the pilot has lit, manually turn off the fuel supply. The controller should lock out on flame failure. If not, then the controller is detecting a false flame signal. Find the problem and correct it before resuming normal operation.

Main Flame Failure Test

- 1) Put the control in the "run" position (see step 6 of Minimum Pilot Test above).
- 2) Start the system normally.
- 3) After the sequence lights the main flame, manually shut off the fuel supply. If the control does not shut down in less than 4 seconds after visually observing that the flame extinguished, it may be detecting a false flame signal. Find the problem and correct it before resuming normal operation.

Process Conditions Test

- 1) Start the system normally.
- 2) Observe the flame signal as the system operates at various firing rates under process (at temperature) conditions.
- 3) Perform the Main Flame Failure Test under these conditions and verify that the control shuts down in less than 4 seconds after visually observing that the flame extinguished.

Limit & Interlock Tests

Periodically check all interlock and limit switches by manually tripping them during burner operation to make sure they cause a system to lock out.



Warning: *Never operate a system that is improperly adjusted or has faulty interlocks or limit switches. Always replace faulty equipment with new equipment before resuming operation. Operating a system with defective or bypassed safety equipment can cause explosions, injuries, and property damage.*

4.0 Maintenance



Caution: High Voltage, turn off power before disconnecting or installing sensors or controls.

All burner systems must be maintained to insure their safe operation. The operator of this equipment must be trained in safe operating procedures. The owner and operator must set a regularly scheduled maintenance interval based on recommendations from the equipment manufacturers, environmental conditions, and their own operational history.

System Checks

Periodically test the sensors as described in Section 3.0.

Sensor Lens

Clean the lens regularly with a soft, damp cloth. The presence of foreign material will measurably reduce the flame signal strength.

Rotation

To insure operability of stored items and to reduce the possibility of extended down-time, periodically swap spare sensors and control units with active ones.

5.0 Dimensions

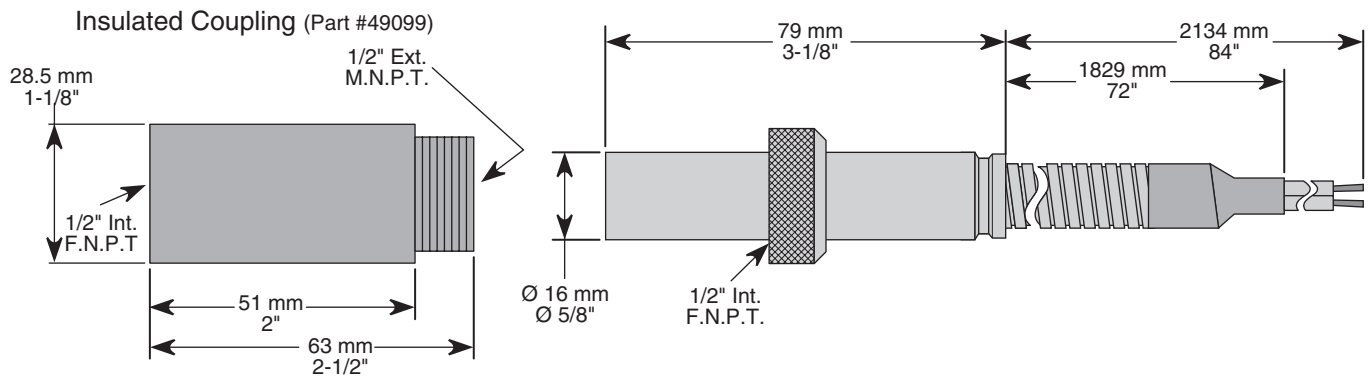



Offered By:

Power Equipment Company
2011 Williamsburg Road
Richmond, Virginia 23231
Phone (804) 236-3800
Fax (804) 236-3882

www.peconet.com